



EMAS ELEKTROTEKNİK MAKİNA
SANAYİ VE TİCARET A.Ş

Ziya Gökalp Mah. İkitelli Organize Sanayi Bölgesi
Atatürk Bulvarı No:50 34490 Başakşehir / İstanbul /
TÜRKİYE

Telefon : +90 212 549 22 52

Faks : +90 212 549 25 80

Web : www.emasas.com.tr

Technical Specifications : L5K13PUM211

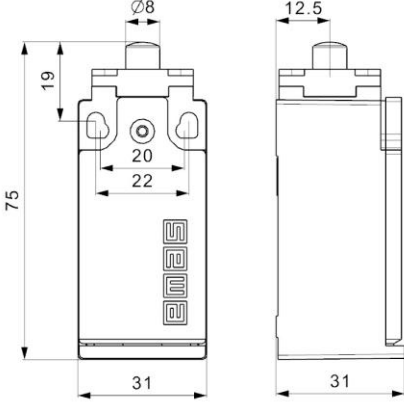

Order Code:

L5K13PUM211

Contact Block:

1NO + 1NC

Snap action

Finger protection terminals

Screw washer

Electrical insulated

Snap action

Technical Information :

Body:

Fireproof plastic body

PG13,5 cable entry

Standards:

- TS EN 60947 -5-1

General Specifications

| | |
|---------------------------------|-----------------------------------|
| Operating Temperature | -5/+40°C |
| Mechanical life | 10 Million (3000 open-close/hour) |
| Electrical Life | 1 Million (1800 open-close/hour) |
| C.Block Tightening Torque | 0,6-0,8 Nm |
| C.Block Connection Wire Profile | Min: 1x0,5 mm ² |
| Wire Profile | Max: 2x2,5 mm ² |
| Protection Degree | IP65 |

In contact Blocks ;

- VDE 0660

- UL 508



Electrical Informations :

General Specifications

| | | |
|---------------------------|------|----------|
| Range Of Use | | AC15 |
| Operating Voltage | Ue | 240V AC |
| Freguency | f | 50Hz |
| Operating Current | Ie | 3A |
| Insulation Resistance | Ui | 300V |
| Stroke Resistance Voltage | Uimp | 2,5kV |
| Dielectrical Strength | | 1500V AC |